



CONVEYOR ROLLERS
for Material Handling



driven rollers

gravity rollers

custom rollers

About Us

daRoller started in 2014. We serve manufacturers of conveying systems located in the US, Canada, Central and South America across a broad range of industries.

We are the exclusive distributor and licensee of Damon rollers and bearings in the Americas.

daRoller was started because we saw that conveyor manufacturers need a supplier who is quick, agile, and willing to do what others are not willing to do. Our daRoller team will analyze your unique needs and we'll tailor a solution for you.

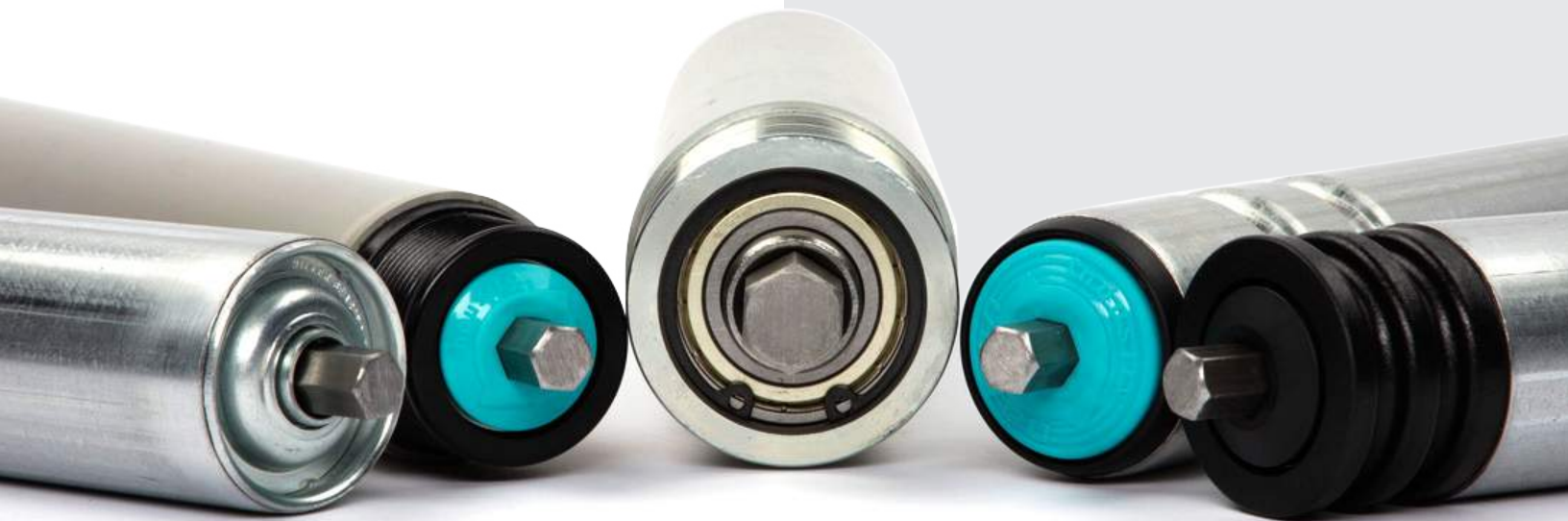



da Roller

Conveyor Rollers for Material Handling

CONTENTS

Roller Overview

2 - 13

Conveyor Roller Selection	2
Load Capacity	4
Tube Material	5
Tube Surface Treatment	6
Shaft	8
Bearing	10
Roller Part Number (order code)	11

Gravity Conveyor Roller Series

14 - 20

1100 Series Light/Medium Duty Conveyor Roller	16
1200 Series Universal Conveyor Roller	18

Driven Conveyor Roller Series

22 - 43

2230 Series Single Grooved O-Belt Conveyor Roller	26
2240 Series Double Grooved O-Belt Conveyor Roller	28
2250 Series Poly-V Conveyor Roller	30
2260 Series O-Belt Conveyor Roller	34
2311/2321 Series Steel Single/Double Sprocket Roller	38
2C21 Series Sprocket Roller	42

Curve Conveyor Roller Series

44 - 53

1600 Series Gravity Tapered Sleeve Roller	48
2640 Series Double Grooved Tapered Sleeve Roller	50
2650 Series Poly-V Tapered Sleeve Roller	52

Conveyor Roller Selection

Is the product suitable for a roller conveyor?

Products:

A Product with a hard and flat bottom surface such as cardboard, flat bottom plastic boxes, metal work bins, wooden pallets, etc. are suitable for roller conveyors. Product with a bottom surface that is soft or irregular such as soft boxes, bags, components with an irregular bottom etc. are not suitable to be conveyed on a roller conveyor.



⚠ Objects with a small contact surface i.e. point contact or line contact, may damage the roller (localized abrasion, damage to the tapered sleeve, etc.)

Environment:

Plastic components are fragile at low temperatures. Different series rollers are suited to different temperatures (check characteristics for each series). When exceeding the specified temperature range, please contact us.

Roller Length

The suitable length of the roller should be selected according to the width of the product (length of roller surface, indicated by W). For straight conveying, calculate according to the formula below:

$$W = B + \Delta B$$

In the formula:

B = width of goods

ΔB = clearance, typically add 50 – 150 (mm)

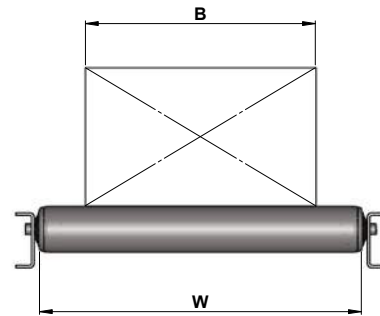

⚠ For curved conveying, please refer to page 47 for roller length selection.

For goods with a sturdy base, where safety and normal conveying is not compromised, the width of the goods can exceed the width of the roller.

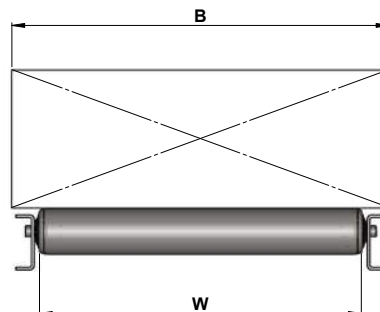



Roller Pitch

To ensure proper conveying of goods, the principles of selecting the correct roller pitch (roller center distance, indicated by T) is a minimum 3 rollers to support the goods at any moment, i.e. $T \leq 1/3L$. Some products may require a closer pitch.

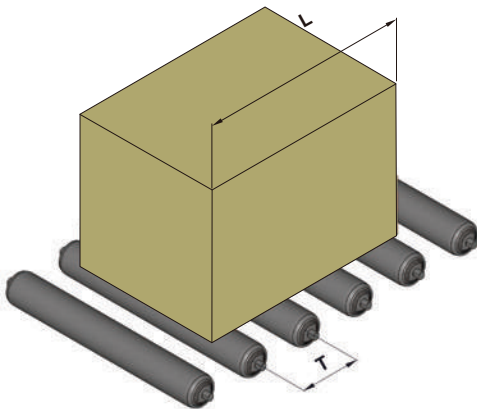

1. The pitch of double sprocket conveyors must be calculated in multiples of $1/2$ the chain pitch.
2. The pitch of poly-V rollers is limited by the type of poly-V roller.

Different Conveying Modes

1. Gravity conveying: Manual pushing or declined roller bed:
 - Polymer bearing housing: **1200 series (black cap)**
 - Non-precision steel bearing housing: **1100 series**
2. Powered conveying: AC gear motor drive or motor roller drive:
 - O-ring conveyor roller: **2230/2240 series**
 - Poly-V conveyor roller: **2250 series**
3. Curve conveying:
 - Segmented plastic tapered roller: **1600, 2640, 2650 series**

Load Capacity

The main factors which determine the roller load capacity are the tube, shaft and bearing. The load capacity is dictated by the weakest of them:

1. Excessive load will distort the tube during roller operation which may result in permanent damage leading to unstable conveying of the product.
2. If the load capacity of the shaft is insufficient, it will change the capacity of the bearing and influence the running performance.
3. If the load exceeds the permitted load of the bearing, it will greatly reduce the bearing's lifespan.

Roller capacity is based on:

1. The load of a single roller is uniformly distributed on the roller surface (not point load).
2. The method of mounting the shaft to the conveyor frame. For example a internal threaded shaft has a higher load capacity than a spring loaded shaft.
3. Steel tube and stainless steel tube have similar mechanical properties with regards to load capacity, so they are typically considered to have same load capacity.
4. Increasing the thickness can strengthen the tube's impact resistance (not easy to dent), but has little influence on the roller's load capacity.
5. In some modes of conveying, especially in belt driven conveying, duty plays a decisive role rather than the load. The duty depends on the driving force such as belt and chain tension.

 Duty: Maximum conveying capacity of driven roller.
Load: Roller's maximum load capacity.



Tube Material

Steel

Steel tubes with precision welding become the most commonly used material for conveyor roller manufacturing. Precision welding tube satisfy the requirements for mechanical properties and curvature, and the advantages are appearance, balance and cost.

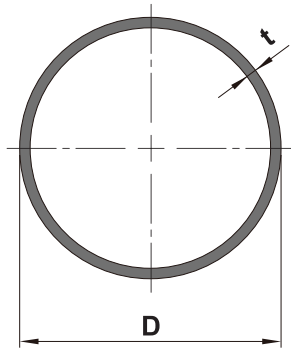

Common Steel Tube size:

Tube Diameter (D) IMPERIAL (inches)	Tube Diameter (D) METRIC (mm)	Wall thickness (t)
Φ 1.375	Φ 35	18ga/1.2mm
Φ 1.9	Φ 48.6/48.3	16ga/1.6mm
Φ 2.5	Φ 63	11ga/3.0mm

Aluminum

The hardness of aluminum alloy is only 1/3 in comparison to steel tube and stainless steel tube. It weighs only 36% of steel tube and is suitable for light weight applications.

PVC

The load capacity of PVC tube is much lower than steel tube of the same diameter but has the following features:

1. Corrosion resistant, good chemical stability.
2. Easy cleaning.
3. The roller is light, easy start-up.
4. Low noise.

Stainless Steel

Welded stainless steel tube is a commonly used material for conveyor rollers. It has an attractive appearance, good corrosion resistance and is much more durable than common steel tube.

Tube Surface Treatment

Galvanized

Forms a homogeneous, compact, well combined zinc coating through electrolysis. Compared with other metal, zinc is economic and easy to use for coating. Corrosion prevention plating allows zinc to be used widely in the area of steel parts protection, especially in preventing oxide etch and is a common surface treatment for conveyor rollers.

1. The typical thickness of the zinc layer for rollers is 0.5 mil.
2. Sealing ensures galvanized tube is more rust resistant than uncoated tube.
3. Galvanizing does not have strong resistance to abrasion. It will wear gradually during operation. If required, you can choose hard chrome plating or other surface treatments.

Urethane Sleeve

For effectively improving conveying efficiency, eliminating slip such as specified area acceleration, small inclines, etc., friction is needed between the contact surfaces. Roller lagging is the most commonly used method. It may also provide protection to the conveyed surface of the product and reduce the conveying noise.

Urethane:

1. High elasticity under room temperature.
2. Good mechanical hardness, small loss on lag.
3. Good electrical insulation properties.
4. Alkali resistant. No resistance to strong acids.
5. Low resistance to oil and solvent.
6. Provide quiet operation.
7. Can be different hardness but most common is 83A.



PVC Sleeve

As an alternative to traditional urethane lagging, you can select PVC sleeving which has similar properties. The PVC sleeve has increased friction, bottom surface protection and reduced noise. It has a short lead time and is more cost effective.

Material	Soft PVC
Tube diameter	Φ48.6/48.3mm
Thickness	2mm
Color	Grey, RAL7042
Hardness	Shore(A) 63±5
Resistance	No resistance to oil and gasoline
Electrical insulation	Non-conducting
Suitable temperature	-25°C – +50°C
Other	Not food grade material

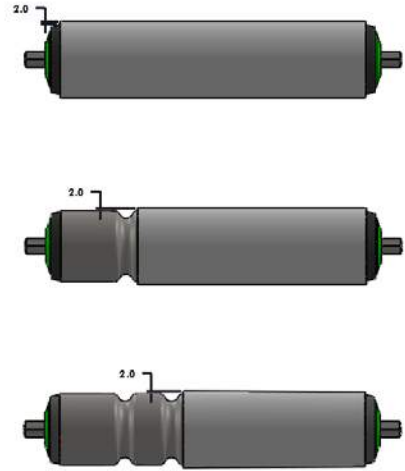

⚠ Typically the sleeve covers the roller's outside surface (as picture) but not between the grooves or between the end of the roller and the first groove.

Shaft

The total load on the roller is borne by the shaft which must sustain the entire weight. daRoller uses carbon steel as the shaft material. Stainless or aluminum axles are available.

Shaft Size

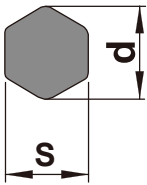

Hexagonal shaft:

SΦ = 5/16", 7/16", 11/16" hex

Installation Method

There are several types of roller installation. Different installation methods influence the load capacity of the roller.

Following are examples of common installation methods and their features. Installation method can be customized.

Spring loaded:

1. This is the most popular installation method for rollers. Assembly and disassembly is simple and quick.
2. Installation clearance is required between the inner width of the frame and the roller. Different clearances are required for different roller diameters, shaft diameters and height of roller. Typically allow 1/16" gap each side.
3. Cross braces are required between the frames to stabilize and reinforce the conveyor.
4. All rollers are spring loaded both ends as standard.

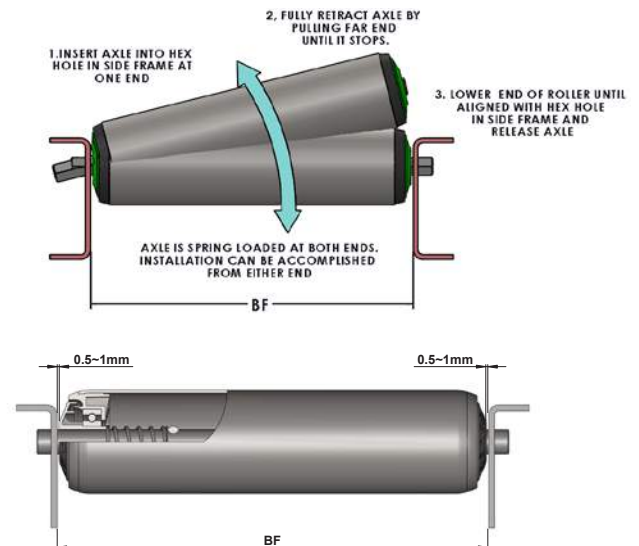



Internal thread:

1. The roller is fastened to the frame with a bolt on each end.
2. Assembly and disassembly is more time consuming.
3. Bolt hole clearance in the frame should not be too large. Typically the clearance should be 0.5mm. For example, for an M8 bolt the recommended mounting hole is $\Phi 8.5\text{mm}$.

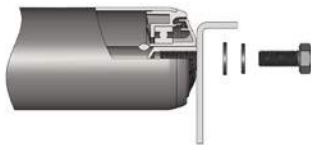
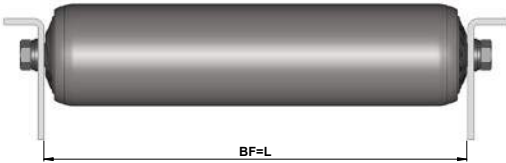

Bearing

The bearings are the most important component of the roller. The correct choice of bearing directly determines the reliability and lifespan of the roller.

Common Types

Depending on the roller application, the roller will utilize different types of bearings with the appropriate tolerance, lubrication and seal.

Lubrication:

1. Good adhesion, difficult to run off and leak.
2. Lubricated for life, no need to regrease.

Clearance:

The clearance of the bearing ensures the bearing runs freely, smoothly and without resistance. To ensure the bearing runs reliability and the axis remains centered, the number of balls to bear the load is maximized.

Seal:

The purpose of the bearing seal is to prevent inner grease from leaking and outside contaminants such as dust, water and other contaminants from entering into the inside of the bearing. The seal ensures the bearing runs with the utmost sustainability.

We use the RZ sealing method which combines the advantages of both the RS and ZZ. It has the same low friction as the ZZ and also has similar seal and dust proof performance to the RS.



Roller Part Number

E. G. : 2 3 2 1 - J H A . A C C - 0 8 0 0 - A - A

①
②
③
④
⑤
⑥

① Series Feature

The specifications and details including conveying method, structural features, driving mode. The first character refers to the roller's conveying method.

- 1 = gravity conveyor roller series
- 2 = driven conveyor roller series
- 3 = accumulating conveyor roller series

② Tube Features

The specifications and details of roller tube material, diameter and surface treatment.

③ Shaft Features

The specifications and details of shaft material, diameter, surface treatment and installation method.

④ Roller BF

Roller's 4-digit BF in millimeters. This may vary between different types of rollers. Use W to indicate width.

⑤ Shaft Length (A = standard length)

⑥ Bearing Type

⚠ Frame inner width:
Use BF to indicate the distance between two frames. Generally this is the key factor in determining the roller length. Please use "BF" as the basis of calculating the length when selecting rollers.

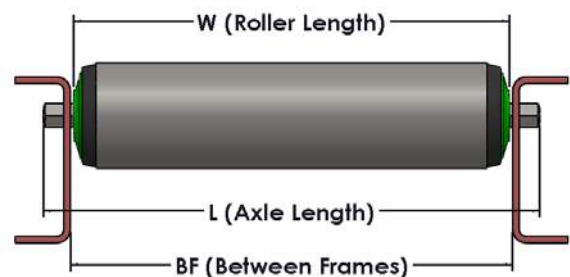

Roller Part Number

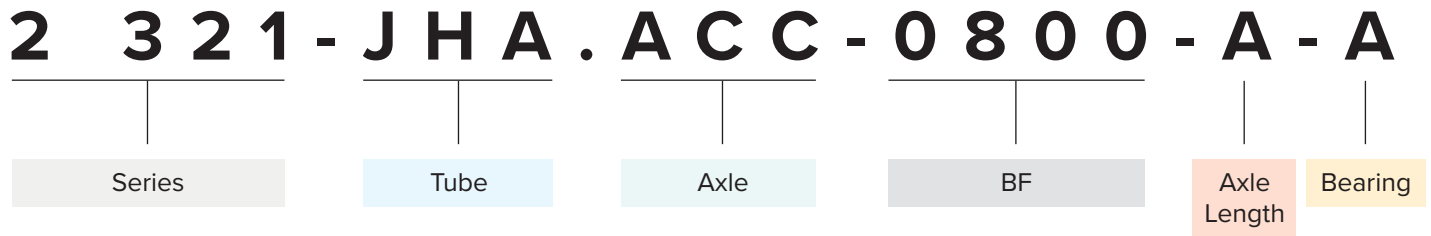

Part Numbering System

Series	
#	###
1 = no driver (no grooves, no poly-v, etc)	100 = less than precision bearings 200 = precision bearings
2 = with driver (no grooves, no poly-v, etc)	230 = one groove; precision bearings 240 = two grooves; precision bearings 250 = poly-v; precision bearings 260 = poly-o; precision bearings 311 = steel one-sprocket hub 321 = steel two-sprocket hub C21 = welded sprockets on OD of tube 600 = tapered no driver 630 = tapered one-groove 640 = tapered two-groove 650 = tapered poly-v

Tube		
A	B	C
Finish J = Mill Finish Steel N = Stainless Steel A = Aluminum Pipe P = PVC Pipe S = PreGalv or ZAM	Size D = 38 x 1.2 A = 1 3/8 x 18ga G = 48.6 x 1.5 N = 1.9 x 16ga H = 50 x 1.5 W = 50 x 2 O = 60 x 2 Q = 2.5 x 11ga S = 76 x 3 Z = 1.9 x 12ga	Cover C = No Surface treatment A = Zinc plated/galv D = Steel w PVC cover V = Steel w PU cover E = Steel w rubber lagging S = Steel w PU lagging



Axle		
A	B	C
Finish	Size	Retention
A = Mill Finish Steel	C = 12mm dia	A = Spring load
B = Zinc plated	D = 15mm dia	B = Flat mill
N = Stainless	E = 20mm dia	C = Female thread
D = Aluminum	B = 8mm dia	S = Double Spring
	F = 7/16 (11mm) hex	
	A = 6mm or 1/4" dia	
	H = 5/16 hex	
	J = 11/16 hex	
	L = Compound 14mm dia	

BF (mm)
####

BF in millimeter (4 digits)

Axle lgth
A

A = standard lgth
= non-standard lgth in mm

Bearing
A

A = 6002RZ ABEC-1
Green End Cap
Greased for 1.9

B = 6002RZ ABEC-1
Black Cap
Oil/Grease Combo
(light running) for 1.9

C = 6002RZ ABEC-1
Green Cap
Stainless Steel for 1.9

D = Non Precision Oiled
Zinc Plated

E = Non Precision Greased
Zinc Plated

F = ABEC-1
Bearings for 1 3/8 rollers

G = ABEC-1
Bearings for 2 1/2" Rollers

H = Stamped Bearings



GRAVITY CONVEYING

Gravity conveyors are the simplest method of conveying goods. Rollers are non-powered. Goods are moved and conveyed by gravity or manually pushed. It is usually arranged horizontally or declined.

Horizontal:



The goods are pushed manually along the conveyor. Suitable for conveying short distances and infrequent work.

Declined:

The goods are conveyed along a declined conveyor by gravity. Increasing the weight of the goods and the angle of the decline increases th



Rollers are listed according to their series and available features.

Products Features	Series	Diameter IMPERIAL (inches)	Diameter METRIC (mm)	Bearings	Page
Non or semi-precision bearing, the ability to withstand impact loads is better than other series.	1100	Φ1 3/8, 1.9, 2.5	Φ 35/48/63.5		16-17
Polymer bearing housing, most popular in carton conveyors and low noise. Available in grease packed or light running.	1200	Φ1 3/8, 1.9	Φ 35/48/		18-19
Steel Housing Precision	1200	Φ 2.5	Φ 63		18-19



1100 Series

Light, Medium Duty Conveyor Roller

Product Features:

- Fitted with non-precision or semi-precision bearings.
- The ball bearing tolerance is greater than a precision ball bearing.
- They can be used in both high and low temperature applications.
- Anti-static design.
- Higher noise levels compared with precision ball bearings.
- Not suitable for powered conveyor.
- Temperature range -4F° – 176°F.

Specifications:

Bearing Unit	
Semi-precision bearing or non-precision	Steel, Zinc plated

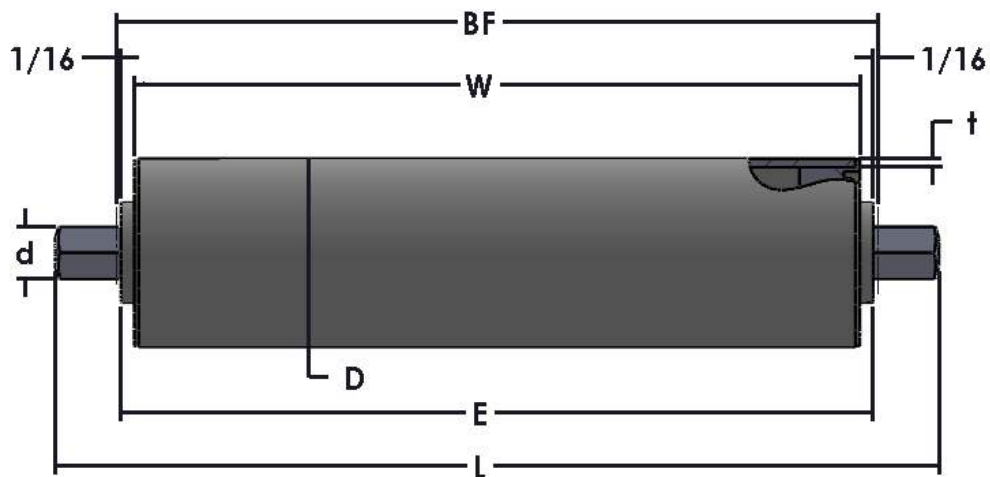

1100 Series

Tube Diameter Imperial (inches)	Tube Diameter Metric (mm)	Shaft	Dimensions
1 3/8"	35	1/4" diameter	BF = E + 1/8"
1 3/8"	35	5/16" hex	BF = E + 1/8"
1.9"	48.3	7/16" hex	BF = E + 1/8"
2.5"	63.5	1 1/16" hex	BF = E + 1/8"

Tube	D*T	Shaft			
		1/4" diameter	5/16" hex	7/16" hex	1 1/16" hex
Galvanized Steel	1 3/8" x 18ga	1100-SAC.AAS	1100-SAC.AHS	-	-
	1.9" x 16ga	-	-	1100-SNC.AFS	-
	1.9" x 12ga	-	-	1100-JNC.AFS	-
	2.5" x 11ga	-	-	-	1100-SQC.AJS

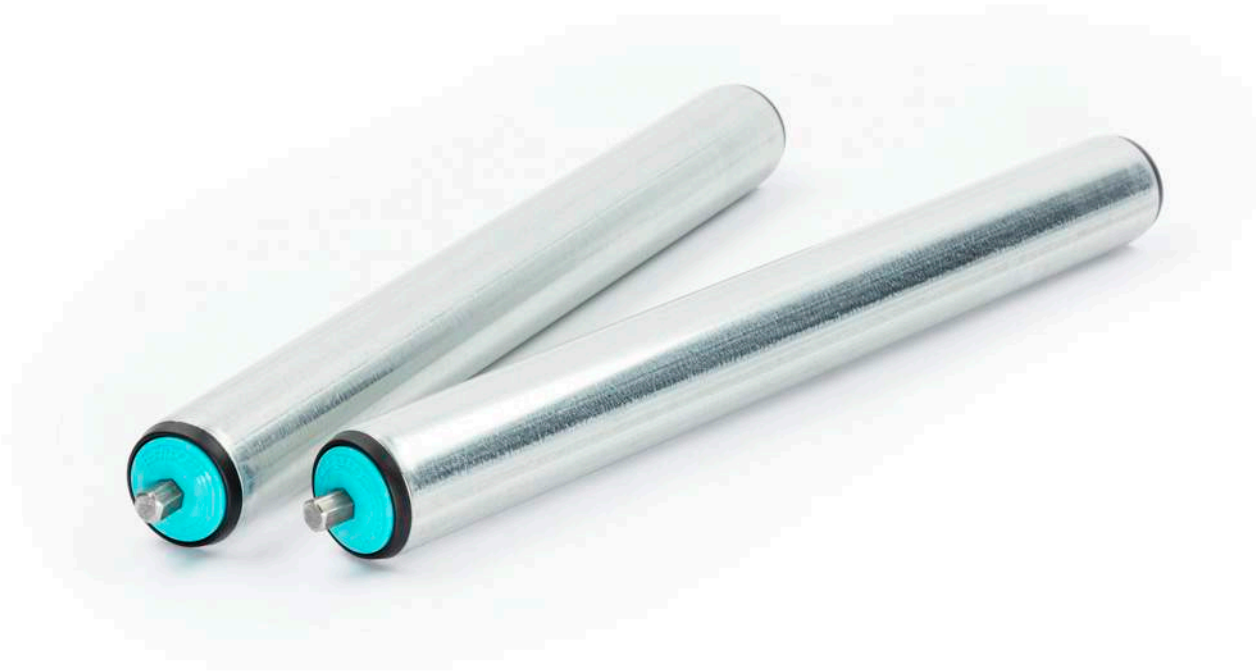

1200 Series Universal Conveyor Roller

Product Features:

- The most widely used and powered in the gravity roller series. Commonly used in carton conveying/gravity applications.
- The bearing end cap consists of a precision ball bearing, which provides a smooth and quiet running roller.
- Can be configured with different bearings according to the application. Can meet the requirements for light gravity chutes.
- Suitable for the high speed applications. Maximum speed varies with roller length and diameter. Maximum speed up to 120m/min.
- Anti-static configuration available (only effective when rolling).
- Temperature range: 23°F – 104°F.

Specifications:

Bearing Unit	
Bearing housing	Polyamide, black
End cap	Polypropylene, daRoller green or black
Precision ball bearing	6002

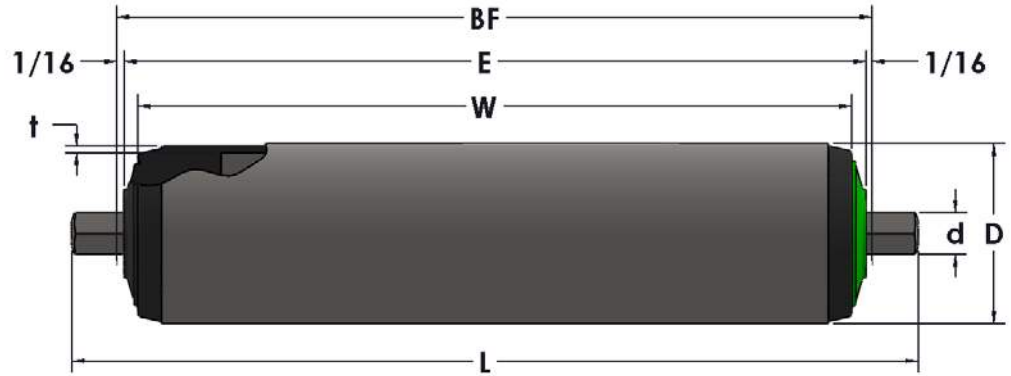

1200 Series Spring Loaded

Tube Diameter Imperial (inches)	Tube Diameter Metric (mm)	Shaft	Dimensions
1 3/8"	35	5/16" hex	BF = E + 1/8"
1.9"	48.3	7/16" hex	BF = E + 1/8"
2.5"	63.5	1 1/16" hex	BF = E + 1/8"

Tube	D*T	Shaft				
		5/16" steel hex	7/16" steel hex	7/16" stainless hex	7/16" alum hex	1 1/16" steel hex
Galvanized Steel	1 3/8" x 18ga	1200-SAC.AHS	-	-	-	-
	1.9" x 16ga	-	1200-SNC.AFS	-	-	-
	1.9" x 12ga	-	1200-JNC.AFS	-	-	-
	2.5" x 11ga	-	-	-	-	1200-SQC.AJS
Stainless Steel	1.9" x 16ga	-	-	1200-NNC.NFS	-	-
Aluminum	1.9" x 16ga	-	1200-ANC.AFS	-	1200-ANC.DFS	-
PVC	50mm x 2.5mm	-	1200-PHC.AFS	-	1200-PHC.DFS	-

Stainless bearings only available in 1.9 grease packed green
PVC available with grease packed or light running bearings and drill & tap available



1200 Series Gravity Conveyor Roller

1200 Series Static Load Capacity

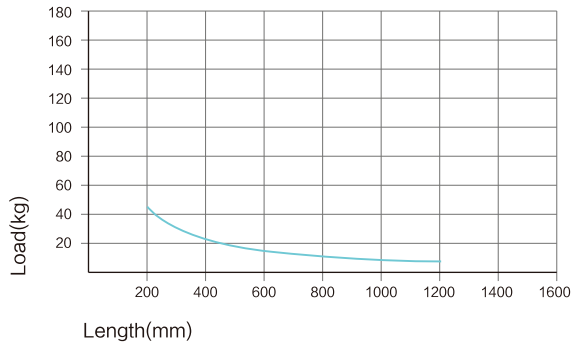

■ Steel tube $\Phi 1 \frac{3}{8} \times 18\text{ga}$, shaft 5/16 hex, spring loaded

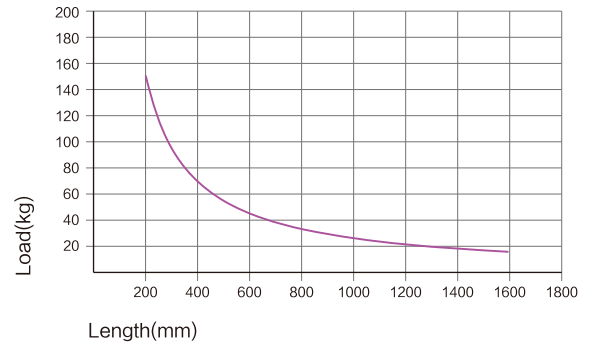

■ Steel tube $\Phi 1.9 \times 16\text{ga}$, shaft 7/16 hex, spring loaded

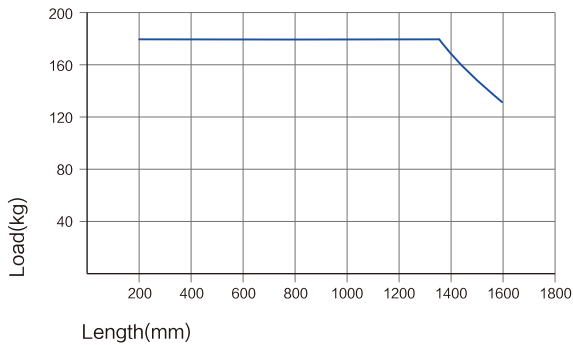

■ Steel tube $\Phi 2.5 \times 11\text{ga}$, shaft 1 1/16 hex, internal thread

⚠ Above data shows the static load capacity of the roller for a uniformly distributed load.
Dynamic load = approx static load x 2.





DRIVEN CONVEYING

Driven conveying transports goods utilizing round belts, Poly-V belts or sprockets to transmit power. According to the driving method, it may be classified as “belt driven conveying” or “chain driven conveying.”

Belt Driven:





Reliable, low noise and able to run at high speed. Oily environments should be avoided.

Chain Driven:

High load capacity. Suitable for a wide range of working environments including oil and higher temperatures. The conveying speed should not exceed 30m/min. (100FPM)



Rollers are listed according to their series and available features.

Products Features	Series	Driving	Diameter IMPERIAL (inches)	Diameter METRIC (mm)	Page
O-belt drive, light/medium duty conveying, widely applied in carton conveying, custom groove position.	2230		Φ1 3/8, 1.9, 2.5	Φ35/48/63	26-27
	2240				28-29
	2260				34-36
Poly-V pulley, medium duty conveying, high speed, low noise.	2250		Φ1 3/8, 1.9, 2.5	Φ48/50	30-33
Chain driven	23 11-21 2C21		Φ1.9, 2.5	Φ48/63	38-43

About Duty

1. Duty is the maximum conveying capacity of driven roller (it's not the roller's maximum load capacity). For more information about the load capacity, refer to the load capacity of 1200 series 1.9" diameter roller on page 20.
2. In driven conveying, duty plays a decisive role.
3. The duty capacity of the rollers depends on the drive method and drive capacity of the O-belt. Product should not exceed 65lb (30kg).

Standard Groove Location

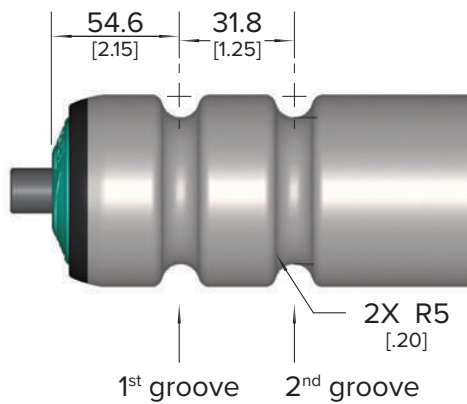

Double Grooved Drive

1. Simple arrangement. Easy installation and maintenance.
2. The driving torque deteriorates rapidly from roller to roller. typically single MDR can only drive 8-9 rollers. The weight of a single item to be conveyed should not exceed 65lb (30kg).

Double Grooved Drive Layout:

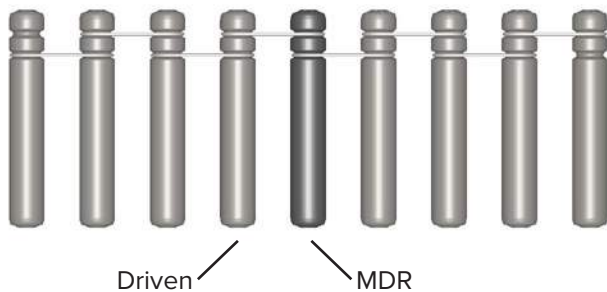





2230 Series

Single Grooved Conveyor Roller

Product Features:

- Compared with chain drive, the O-belt drive has the advantages of low noise and high speed. It is widely used for light/medium duty carton conveying.
- The bearing end cap consists of a precision ball bearing, a polymer housing and end cap seal. Combined they provide a smooth and quiet running roller.
- The design of the end cap protects the bearings by providing excellent resistance to dust and splashed water.
- The position of the grooves can be customized.
- Anti-static design (only effective when rolling).
- Temperature range: -5°C – +40°C.

Specifications:

Bearing Unit	
Bearing housing	Polyamide, black
End cap	Polypropylene, daRoller green
Precision ball bearing	6002

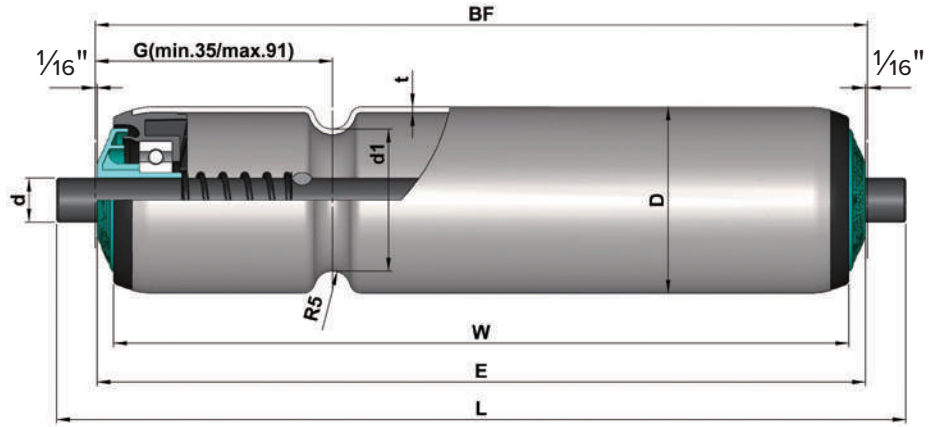

G std groove 55mm & 87mm

2230 Series Spring Loaded

Tube Diameter Imperial (inches)	Tube Diameter Metric (mm)	Shaft	Dimensions
1.9"	48.3	7/16" hex/11mm	BF = E + 1/8"

Tube	D*T	Shaft	
		7/16" steel hex	7/16" stainless hex
Galvanized Steel	1.9" x 16ga	2230-SNC.AFS	-
Stainless Steel	1.9" x 16ga	-	2230-NNC.NFS



2240 Series

Double Grooved Conveyor Roller

Product Features:

- Compared with chain drive, the O-belt drive has the advantages of low noise and high speed. It is widely used for light/medium duty carton conveying.
- The bearing end cap consists of a precision ball bearing, a polymer housing and end cap seal. Combined they provide a smooth and quiet running roller.
- The design of the end cap protects the bearings by providing excellent resistance to dust and splashed water.
- Anti-static design (only effective when rolling).
- Temperature range: -5°C – +40°C.

Specifications:

Bearing Unit	
Bearing housing	Polyamide, black
End cap	Polypropylene, daRoller green
Precision ball bearing	6002

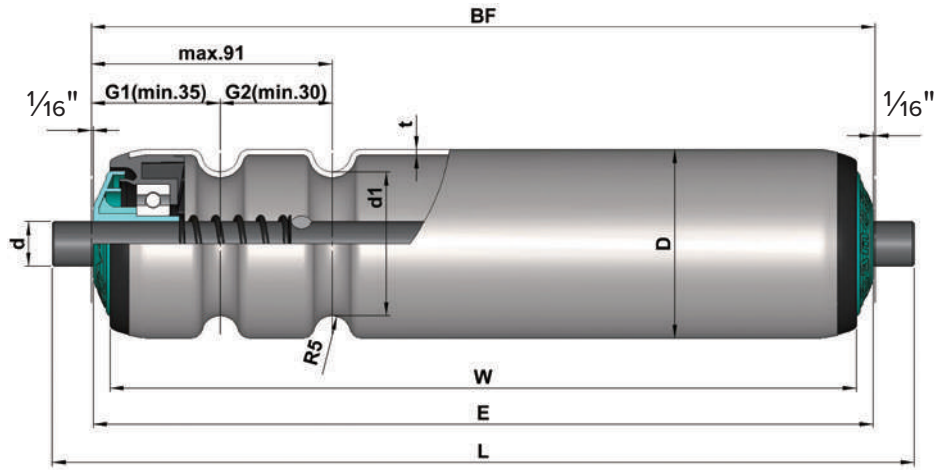

2240 Series Spring Loaded

Tube Diameter Imperial (inches)	Tube Diameter Metric (mm)	Shaft	Dimensions
1.9"	48.3	7/16" hex/11mm	BF = E + 1/8"

Tube	D*T	Shaft	
		7/16" steel hex	7/16" stainless hex
Galvanized Steel	1.9" x 16ga	2240-SNC.AFS	-
Stainless Steel	1.9" x 16ga	-	2240-NNC.NFS



2250 Series Poly-V Conveyor Roller

Product Features:

- The poly-V pulley is located at the end of the roller which separates the drive area and the conveying area making the conveying smooth, high speed and low noise.
- For 1 3/8 and 1.9 rollers, the bearing end cap consists of a precision ball bearing, a polymer housing and end cap seal. Combined they provide a smooth and quiet running roller. Poly-V pulleys for 2.5" diameter rollers are steel and welded to the tube.
- ISO9982 PJ series poly-V. Total of 9 grooves at 2.34mm pitch for 1 3/8 and 1.9 rollers. Total of 16 grooves are provided for 2.5" rollers (2 sections of 8 each).
- Various PJ belt lengths available to suit different roller centers.
- Suitable for the high speed applications. Maximum speed varies with roller length and diameter. Maximum speed up to 120m/min.
- Temperature range: -5°C – +40°C.

Specifications:

Bearing Unit	1.9 & 1 3/8	2.5
Bearing housing	Polyamide, black	Steel
End cap	Polypropylene, da Roller green	Steel
Drive Element		
Poly-V wheel	Polyamide, black	Steel

 Poly-vee belts are available.

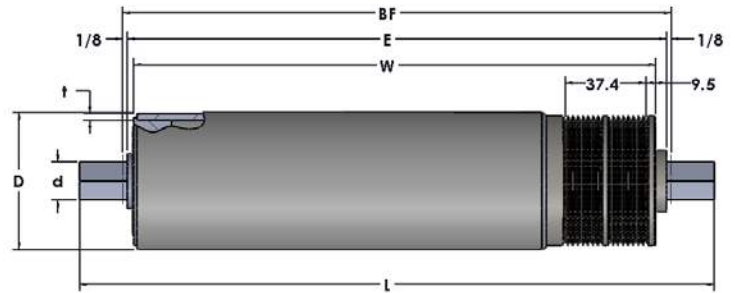
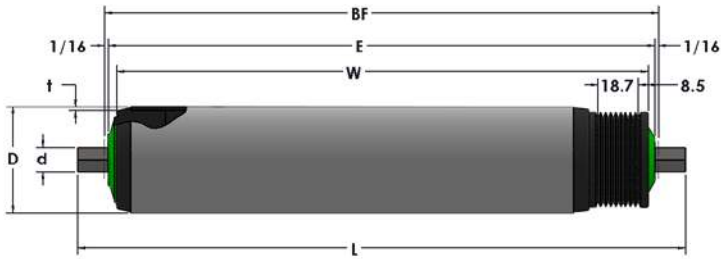

2250 Series **Spring Loaded**

Tube Diameter	Material	Wall Thickness	COVERS				
			Shaft			Polyurethane 85A 1/8"	Soft PVC 63A
			5/16" Hex	7/16" Hex	11/16" Hex	Orange	PVC Gray
1 3/8"	Galvanized	0.048"	★			★	
1.9"	Galvanized	0.06"		★		★	★
	Stainless	0.060"		★		★	★
1.96"	Gray PVC	0.098"		★			★
2.5"	Galvanized	0.12"			★	★	

About Duty

1. Duty is the maximum conveying capacity of driven roller (it's not roller's maximum load capacity). For more information about the load capacity, refer to the load capacity of 1200 series 1.9" diameter roller on page 20.
2. In driven conveying, duty plays a decisive role.
3. The duty capacity of the roller is based on the drive method and the type of Poly-V belt. The duty rating is high when fewer rollers are driven or selecting the 3 or 4 groove Poly-V belt.
4. The duty capacity for each unit can be as high as 220lb (100kg) when the 3 groove poly-vee belt is used.

Roller Center Pitch

Poly-V belt selection according to the roller pitch, please refer to the following chart:

Roller pitch (mm)	Types of poly-V belt for 1.9" diameter	
	2 grooves	3 grooves
60~63	2PJ256	3PJ256
73~75	2PJ286	3PJ286
76~78	2PJ290	3PJ290
87~91	2PJ314	3PJ314
97~101	2PJ336	3PJ336
103~107	2PJ346	3PJ346
119~121	2PJ376	3PJ376
129~134	2PJ416	3PJ416
142~147	2PJ435	3PJ435
157~161	2PJ456	3PJ456



MIN/MAX CENTER DISTANCE FOR 43MM PULLEYS		MIN/MAX CENTER DISTANCE FOR 60MM PULLEYS		# of Ribs + Belt Number = Belt Part Number
Min (mm)	Max (mm)	Min (mm)	Max (mm)	
N/A	N/A	N/A	N/A	PJ206
N/A	N/A	N/A	N/A	PJ214
48.2	51.7	N/A	N/A	PJ236
54.4	58.1	N/A	N/A	PJ246
60.0	64.9	N/A	N/A	PJ256
63.2	67.2	N/A	N/A	PJ263
64.2	68.2	N/A	N/A	PJ265
64.7	68.8	N/A	N/A	PJ270
71.8	76.1	N/A	N/A	PJ282
72.6	76.9	N/A	N/A	PJ286
75.7	80.1	N/A	N/A	PJ290
77.5	81.9	N/A	N/A	PJ292
81.7	86.3	N/A	N/A	PJ302
88.4	93.2	N/A	N/A	PJ314
92.4	97.3	65.7	70.6	PJ316
98.4	103.5	71.7	76.8	PJ336
104.6	109.9	77.9	83.2	PJ346
105.9	111.2	81.7	87.1	PJ348
105.5	110.0	78.8	83.0	PJ354
108.4	113.8	88.5	94.2	PJ372
115.3	120.9	91.4	97.1	PJ376
124.8	130.7	98.1	104.0	PJ388
131.3	137.4	104.6	110.7	PJ401*
134.5	139.5	107.7	113.0	PJ417
144.1	150.6	117.4	123.9	PJ435
152.1	158.9	125.4	132.2	PJ442
157.3	164.2	130.6	137.5	PJ456
172.4	179.7	145.7	153.0	PJ486
185.2	192.9	158.5	166.2	PJ515
198.2	206.4	171.5	179.7	PJ536
209.9	218.5	183.2	191.7	PJ570
224.0	233.8	197.3	207.0	PJ583
250.0	262.8	223.3	236.1	PJ636
304.0	315.4	277.3	288.7	PJ746
409.7	424.4	383.0	397.7	PJ955
522.3	540.4	495.6	513.7	PJ1215



2260 Series

O – Belt Pulley Roller

Product Features:

- The O–belt pulley is located the end of the roller which separates the drive area and the conveying area avoiding interference between the O–belt and the conveyed goods.
- The bearing end cap consists of a precision ball bearing, a polymer housing and end cap seal. Combined they provide an attractive, smooth and quiet running roller.
- Temperature range: -5°C – +40°C.

Specifications:

Bearing Unit	
Bearing housing	Polyamide, black
End cap	Polypropylene, daRoller green
Precision ball bearing	6002
Drive Element	
O–belt pulley	Polyamide, black



About Duty

1. Duty is the maximum conveying capacity of driven roller (it's not roller's maximum load capacity). For more information about the load capacity, refer to the load capacity of 1200 series 1.9" diameter roller on page 20.
2. In driven conveying, duty plays a decisive role.
3. The duty capacity of the rollers depends on the drive method and drive capacity of the O-belt. Single items should not exceed 65lb (30kg).

Double Groove Pulley Drive

1. Simple arrangement. Easy installation and maintenance.
2. The driving torque deteriorates rapidly from roller to roller. Typically single MDR can only drive 8-9 rollers. The weight of single items to be conveyed should not exceed 65lb (30kg).

Double Groove Pulley Drive Layout:

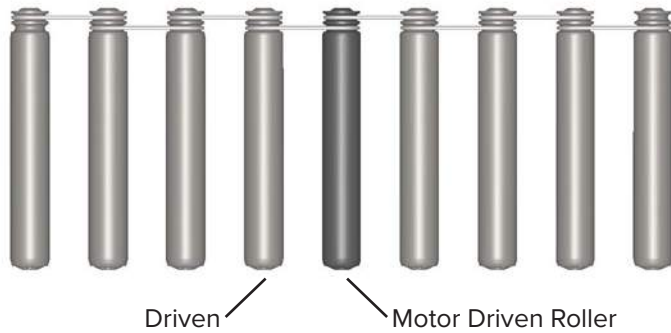

Double Groove Pulley Drive Layout:

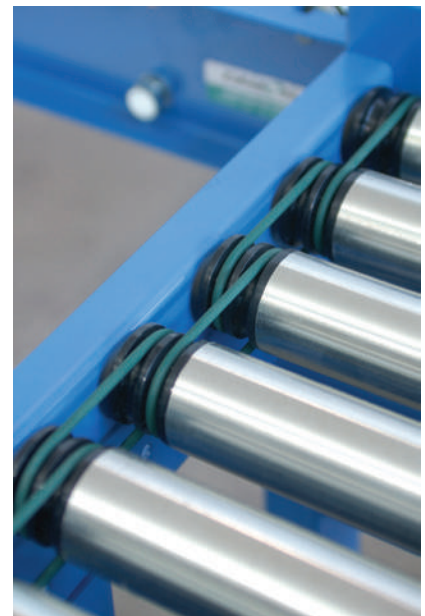



2260 Series Driven Conveyor Roller

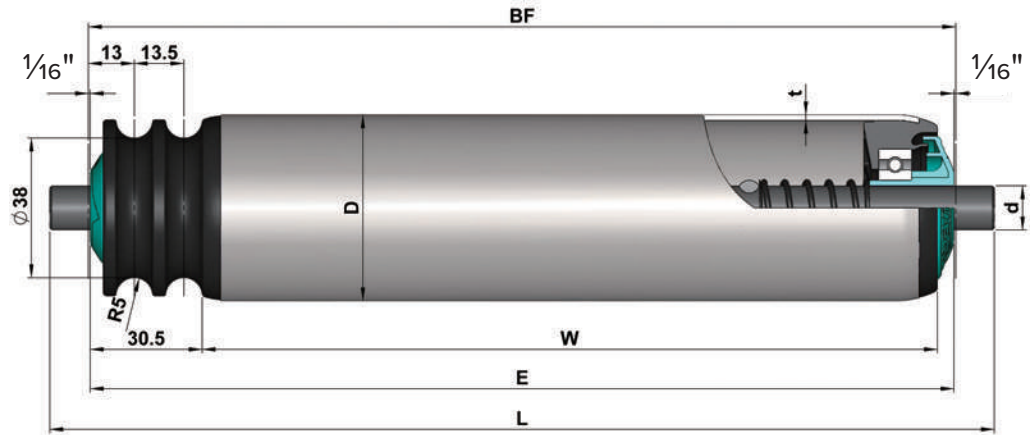

2260 Series Spring Loaded

Tube Diameter Imperial (inches)	Tube Diameter Metric (mm)	Shaft	Dimensions
1.9"	48.3	7/16" hex/11mm	BF = E + 1/8"

Tube	D*T	Shaft
Steel, zinc plated	1.9" x 16ga	7/16"
		2260-SNC.AFS





2311/2321 Series

Steel Single/Double Sprocket Roller

Product Features:

- Welding the steel sprocket to the steel tube gives it the capacity to transmit high torque and meet the requirements for heavy duty transportation.
- The precision ball bearing is pressed tightly into the steel bearing housing for maximum durability.
- The environmental working conditions are broad. They can be used in both high and low temperature applications.
- The covering on the outside of the sprocket protects the bearings by providing excellent resistance to dust.
- Temperature range: -20°C – +80°C.

Specifications:

Bearing Unit	
Bearing housing	Steel, zinc plated
Precision ball bearing	6001/6202/6204
Ground sleeve	Polyamide, black
Drive Element	
Sprocket	Steel



2311/2321 Series Load Capacity

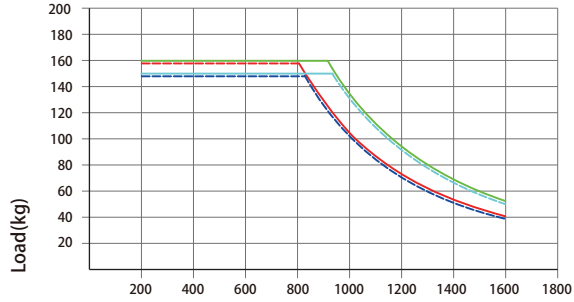

Length(mm)

- Steel tube $\Phi 50 \times 2.0$, shaft $\Phi 15$, internal thread
- Steel tube $\Phi 50 \times 1.5$, shaft $\Phi 15$, internal thread
- Steel tube $\Phi 50 \times 2.0$, shaft $\Phi 12$, internal thread
- Steel tube $\Phi 50 \times 1.5$, shaft $\Phi 12$, internal thread

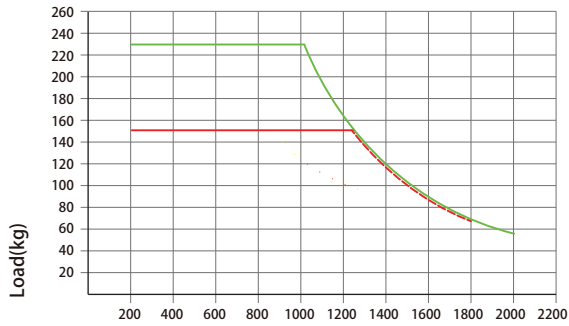

Load(kg)

Length(mm)

- Steel tube $\Phi 60 \times 2.0$, shaft $\Phi 15$, internal thread
- Steel tube $\Phi 60 \times 2.0$, shaft $\Phi 12$, internal thread

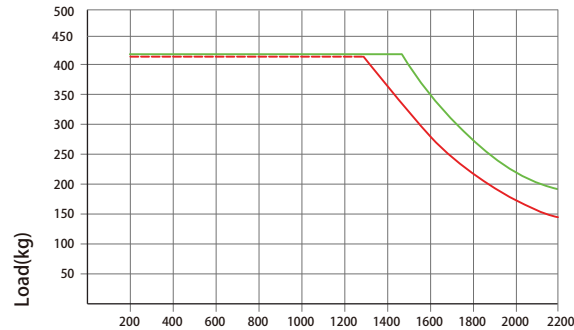

Load(kg)

Length(mm)

- Steel tube $\Phi 76 \times 4.0$, shaft $\Phi 20$, internal thread
- Steel tube $\Phi 76 \times 3.0$, shaft $\Phi 20$, internal thread

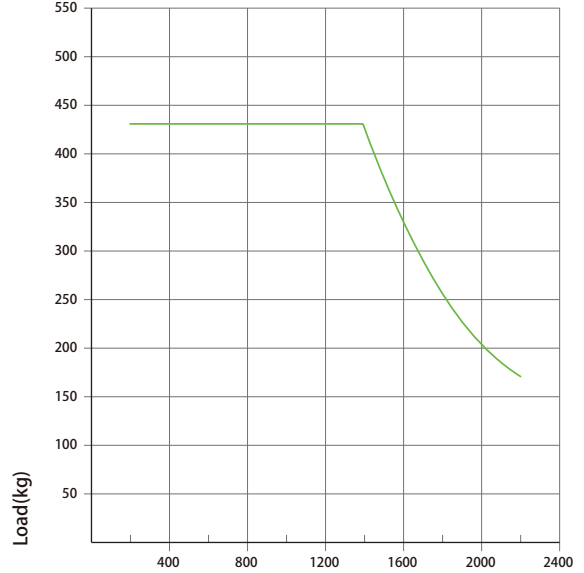

Load(kg)

Length(mm)

- Steel tube $\Phi 80 \times 3.0$, shaft $\Phi 20$, internal thread

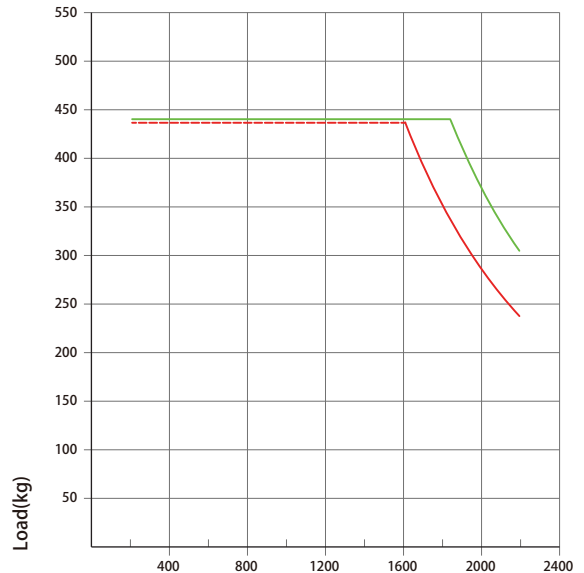

Load(kg)

Length(mm)

- Steel tube $\Phi 89 \times 4.0$, shaft $\Phi 20$, internal thread
- Steel tube $\Phi 89 \times 3.0$, shaft $\Phi 20$, internal thread

⚠ Above data shows the static load capacity of the roller for a uniformly distributed load. You should also consider the chain tension, motor power drive factors, calculation based on the smallest value.

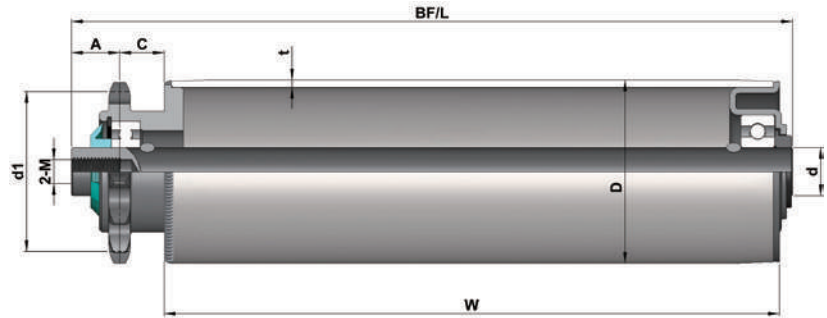

2311 Series Internal Thread

Tube Diameter	Shaft Diameter		Sprocket Style	A	C	d1
Φ50	Φ12	BF/L=W+40	US40#11T	17	18.5	Φ45.08
Φ50	Φ15	BF/L=W+41	US40#14T	17	18.5	Φ57.07
Φ60	Φ12/15	BF/L=W+41	US40#14T	17	18.5	Φ57.07
Φ76	Φ15	BF/L=W+41	US40#14T	17	18.5	Φ57.07
Φ76	Φ20	BF/L=W+44	US50#13T	20	18.5	Φ66.33
Φ80	Φ20	BF/L=W+44	US50#15T	20	18.5	Φ76.35
Φ89	Φ20	BF/L=W+44	US50#15T	20	18.5	Φ76.35

Tube	D*T	Shaft Diameter		
		Φ12 (M8x15)	Φ15 (M10x20)	Φ20 (M12x25)
Steel, zinc plated	Φ50x1.5	2.311.JHA.ACC	○	
	Φ50x2.0	2.311.JWA.ACC	○	
	Φ60x2.0	2.311.JOA.ACC	2.311.JOA.ADC	
	Φ60x3.0		2.311.JLA.ADC	
	Φ76x3.0		○	2.311.JSA.AEC
	Φ76x4.0			2.311.JRB.AEC
	Φ80x3.0			2.311.J6A.AEC
	Φ89x3.0			2.311.JYA.AEC
	Φ89x4.0			○
Steel, zinc plated with steel flange	Φ60x3.0		2.311.JLG.ADC	
	Φ76x3.0			2.311.JSG.AEC
	Φ76x4.0			○
	Φ80x3.0			2.311.J6G.AEC
	Φ89x3.0			2.311.JYG.AEC
	Φ89x4.0			○
Stainless steel (304)	Φ50x1.5	2.311.NHC.BCC	○	
	Φ60x2.0	2.311.NOC.BCC	2.311.NOC.BDC	
	Φ76x3.0		○	2.311.NSC.BEC

○—Available configuration

⚙️ Φ50, 60mm rollers can be fitted with PVC sleeve (2mm).

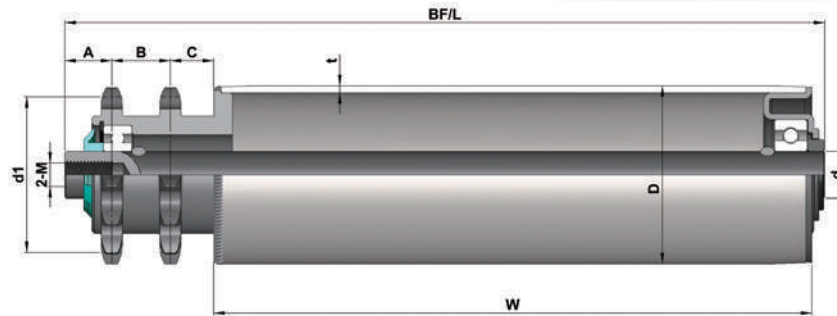

2321 Series Internal Thread

Tube Diameter	Shaft Diameter		Sprocket Style	A	B	C	d1
Φ50	Φ12	BF/L=W+62	US40#11T	17	22	18.5	Φ45.08
Φ50	Φ15	BF/L=W+63	US40#14T	17	22	18.5	Φ57.07
Φ60	Φ12/15	BF/L=W+63	US40#14T	17	22	18.5	Φ57.07
Φ76	Φ15	BF/L=W+63	US40#14T	17	22	18.5	Φ57.07
Φ76	Φ20	BF/L=W+69	US50#13T	20	25	18.5	Φ66.33
Φ80	Φ20	BF/L=W+69	US50#15T	20	25	18.5	Φ76.35
Φ89	Φ20	BF/L=W+69	US50#15T	20	25	18.5	Φ76.35

Tube	D*T	Shaft Diameter		
		Φ12 (M8x15)	Φ15 (M10x20)	Φ20 (M12x25)
Steel, zinc plated	Φ50x1.5	2.321.JHA.ACC	○	
	Φ50x2.0	2.321.JWA.ACC	○	
	Φ60x2.0	2.321.JOA.ACC	2.321.JOA.ADC	
	Φ60x3.0		2.321.JLA.ADC	
	Φ76x3.0		○	2.321.JSA.AEC
	Φ76x4.0			2.321.JRB.AEC
	Φ80x3.0			2.321.J6A.AEC
	Φ89x3.0			2.321.JYA.AEC
	Φ89x4.0			○
Steel, zinc plated with steel flange	Φ60x3.0		2.321.JLG.ADC	
	Φ76x3.0			2.321.JSG.AEC
	Φ76x4.0			○
	Φ80x3.0			2.321.J6G.AEC
	Φ89x3.0			2.321.JYG.AEC
	Φ89x4.0			○
Stainless steel (304)	Φ50x1.5	2.321.NHC.BCC	○	
	Φ60x2.0	2.321.NOC.BCC	2.321.NOC.BDC	
	Φ76x3.0		○	2.321.NSC.BEC

○—Available configuration

⚙️ Φ50, 60mm rollers can be fitted with PVC sleeve (2mm).



2C21 Series Sprocket Roller

Product Features:

- Fitted with non-precision or semi-precision bearings.
- The ball bearing tolerance is greater than a precision ball bearing.
- Anti-static design.

Specifications:

Bearing Unit	
Semi-precision bearing or non-precision	Steel, Zinc plated

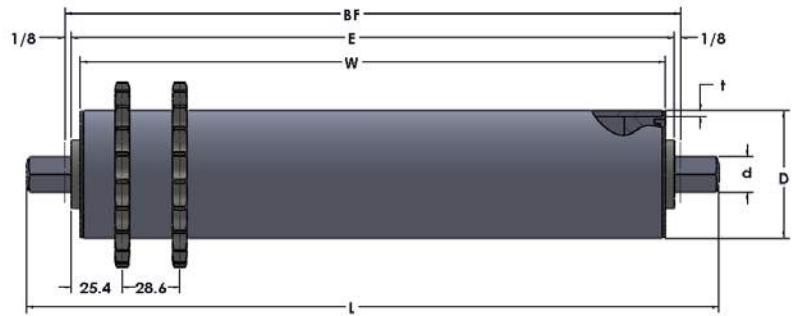
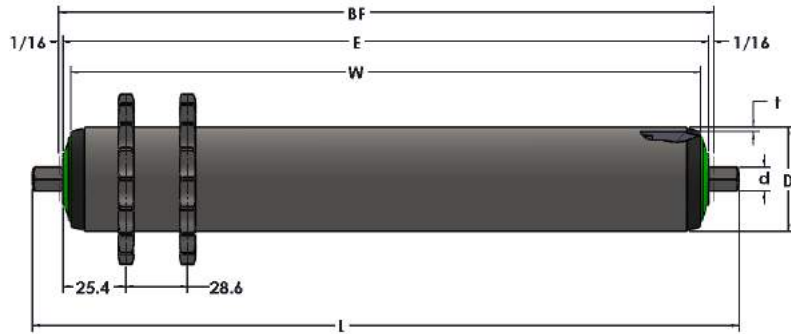

2C21 Series

Tube Diameter Imperial (inches)	Tube Diameter Metric (mm)	Shaft	Dimensions
1.9"	48.3	7/16" hex/11mm	BF = E + 1/8"
2.5"	63.5	1 1/16" hex/17.5mm	BF = E + 1/8"

Tube	D*T	Shaft		
		Sprockets	7/16" steel hex	1 1/16" steel hex
Mill Finish Tube	1.9" x 12ga	40A18	2C21-JZC.AFS	-
	1.9" x 12ga	50A15	2C22-JZC.AFS	-
Galvanized	2.5" x 11ga	40A22	-	2C23-SQC.AJS
	2.5" x 11ga	60A15	-	2C24-SQC.AJS





CURVE CONVEYING

The different diameters over the length the tapered roller i.e. small one end and large the other end, provides a velocity to ensure smooth conveying of goods around the curve.

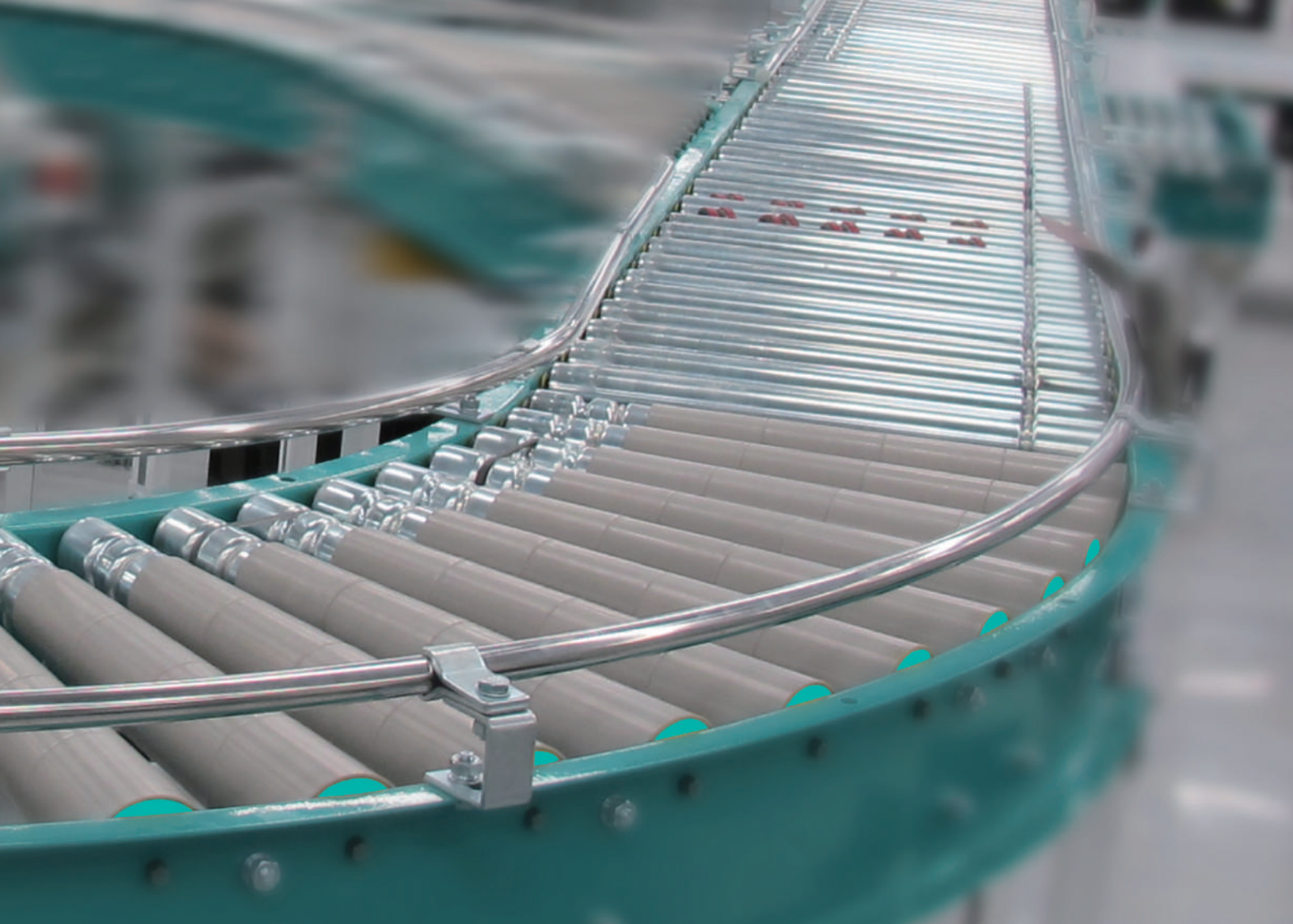



Rollers are listed according to their series and available features.

Products Features	Series	Small Taper Diameter IMPERIAL (inches)	Small Taper Diameter METRIC (mm)	Driving Element	Page
Tapered sleeve, low noise.	1600	Φ2.08", 2.20"	Φ52.9/56		48-49
Tapered sleeve, O-Belt drive, light duty conveying, groove position customized.	2640	Φ2.08", 2.20"	Φ52.9/56		50-51
Tapered sleeve, poly-V drive, medium duty conveying, high speed, low noise.	2650	Φ2.08", 2.20"	Φ52.9/56		52-53

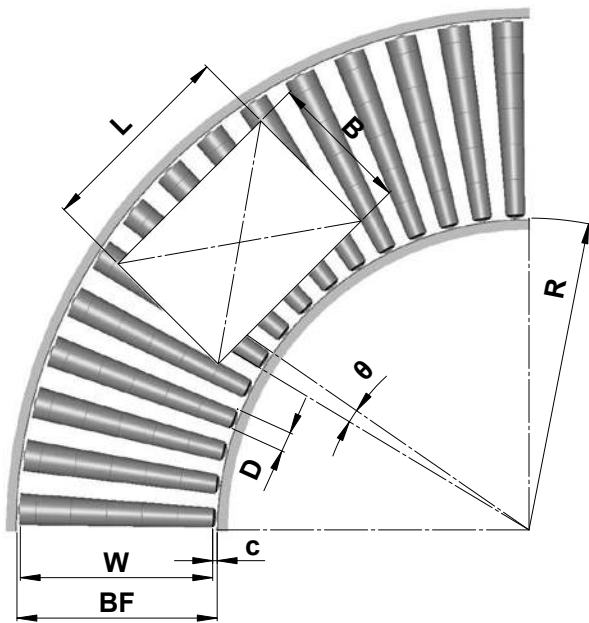

Turn Radius

In theory, the geometric extension line of the tapered roller should join with the center of the radius of the curve frame. By using this method, you can achieve the ideal curve for conveying. It may be calculated using the formula below:

$$R = \frac{D}{K} - c$$

In the formula:

R — turn (inner) radius at inside of frame

D — diameter of the smaller diameter of the taper roller

K — conical degree (the conical degree is expressed by fraction, eg. $\frac{1}{6}$, $\frac{1}{30}$, it's reduction formula is $K=2 \cdot \tan \theta / 2$)

c — the space between the tapered roller's smaller head and the inner side of the frame.

Series	Taper	Small Dia. (D)	Curve Radius (R)
1600	3.6°	52.5	830
2624		55.6	880
2650	3.6°	52.5	800
2660		55.6	850
2640	3.6°	52.5	760
		55.6	810
1500	3.6°	50	790
2521			

Roller Pitch

The design of roller pitch should follow the principle of “minimum 3 rollers to support the goods at any moment” (refer to page 3)

For poly-V tapered rollers the recommended pitch of poly-V pulleys is 73.7mm.

The angle between tapered rollers should not exceed 5°.

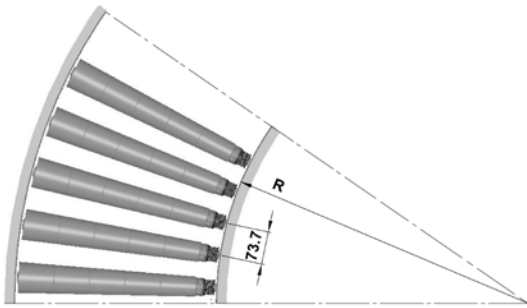

Calculating Roller Length

For straight conveying, generally there is no need to consider the length of the goods but for curved conveying, the length and width of goods and the curve radius are all influencing factors. It may be calculated using the formula below:

$$BF = \sqrt{(R+B)^2 + (L/2)^2} - R + (\text{min.} 125)$$

In the formula:

BF— frame inner width

R — turn (inner) radius

B — width of goods

L — length of goods

After confirming BF, you can calculate the roller length W and taper sleeve length WT by the available series of tapered roller. The tapered sleeve is the working surface of the tapered roller. The tapered sleeve length WT is available in increments of 50mm. Adjust the calculation result based on the formula.

E.g.: $W_{\uparrow}=628$, $WT=595$

$W_{\downarrow}=561$, $WT=545$

⚠ Based on the width of goods, the calculated roller length for a curve is longer than that for a straight conveyor. Typically, the length of the roller for the curve would be used as the default roller length for the entire conveyor system. Where it is not convenient to utilize a uniform roller length, a transitional straight conveyor will need to be installed.



1600 Series Gravity Tapered Sleeve Roller

Product Features:

- Based on the 1200 Series, fitted with a grey polypropylene taper sleeve; abrasion resistant, low noise, shockproof.
- The bearing end cap consists of a precision ball bearing, a polymer housing and end cap seal. Combined they provide a smooth and quiet running roller.
- The design of the end cap protects the bearings by providing excellent resistance to dust.
- The roller is light and easy to start-up.
- The weight of single items to be conveyed should not exceed 110lb.
- Temperature range: 40° to 104° F (-5°C to 40°C).

Specifications:

Bearing Unit	
Bearing housing	Polyamide, black
End cap	Polypropylene, daRoller green
Precision ball bearing	6002

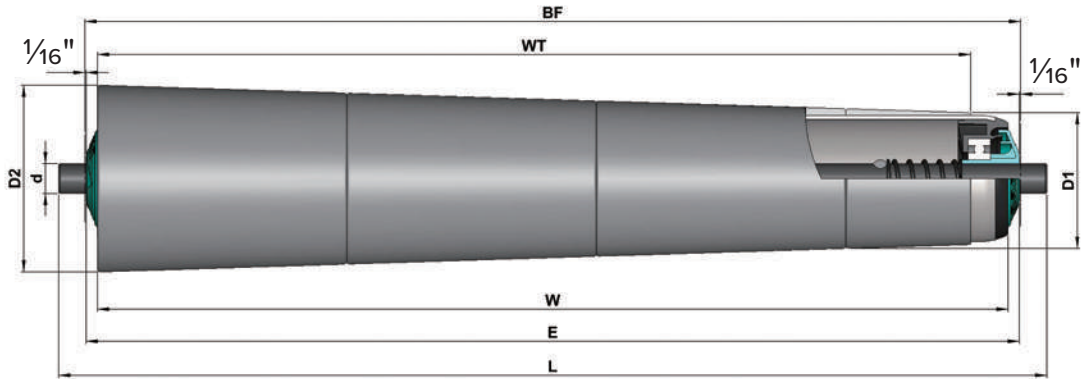

1600 Series

Tube Diameter Imperial (inches)	Tube Diameter Metric (mm)	Hex Shaft	Dimensions
Φ1.9"	Φ50	7/16"/11mm	BF = E + 1/8"

Tube	D*T	WT	D1	D2	Shaft Size
					11hex
Steel, zinc-plated with polypropelene tapered segmented sleeves	Φ50x1.5	295	Φ52.5	Φ71	1600-SHC.AFS
		345	Φ55.6	Φ77.3	
		395	Φ52.5	Φ77.3	
		445	Φ55.6	Φ83.6	
		495	Φ52.5	Φ83.6	
		545	Φ55.6	Φ89.9	
		595	Φ52.5	Φ89.9	
		645	Φ55.6	Φ96.2	
		695	Φ52.5	Φ96.2	
		745	Φ55.6	Φ102.5	
		795	Φ52.5	Φ102.5	
		845	Φ55.6	Φ108.8	
895	Φ52.5	Φ108.8			

Available options:
 • stainless tube, bearings, shaft



2640 Series

Double Grooved Tapered Sleeve Roller

Product Features:

- Based on the 2240 Series, covered with grey polypropylene taper sleeve; abrasion resistant, low noise, shockproof.
- The bearing end cap consists of a precision ball bearing, a polymer housing and end cap seal. Combined they provide a smooth and quiet running roller.
- The design of the end cap protects the bearings by providing excellent resistance to dust.
- The roller is light and easy to start-up.
- The position of the grooves can be customized.
- The duty capacity of the roller depends on the drive capacity of the O-belt. The weight of single items to be conveyed should not exceed 66 lbs.
- Temperature range: 40° to 104° F (-5°C to 40°C).

Specifications:

Bearing Unit	
Bearing housing	Polyamide, black
End cap	Polypropylene, daRoller green
Precision ball bearing	6002

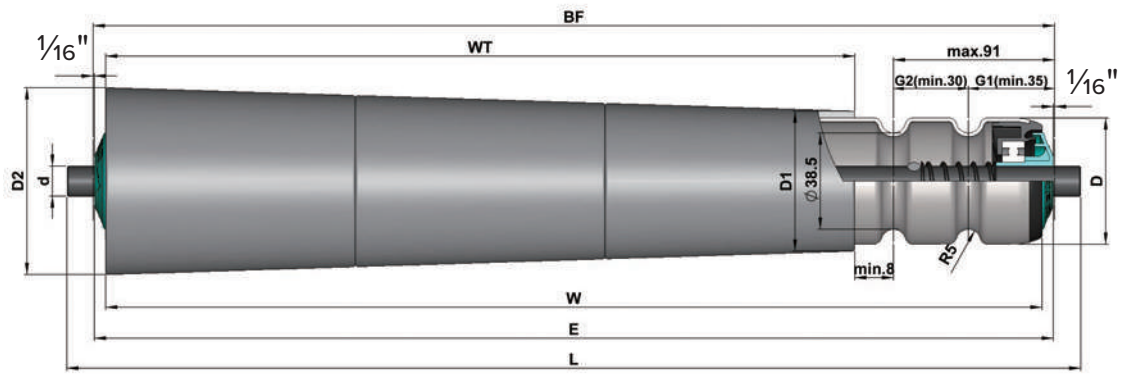

G1 = 55mm std (2.15")
 G2 = 32mm std (1.25")

2640 Series

Tube Diameter Imperial (inches)	Tube Diameter Metric (mm)	Shaft Hex	Dimensions
Φ2.0"	Φ50	7/16"	BF = E + 1/8"

Tube	D*T	WT	D1	D2	Shaft Dia. (d)
					11hex
Steel, zinc-plated with polypropelene tapered segmented sleeves	Φ50x1.5	300	Φ56	Φ74.9	
		350	Φ52.9	Φ74.9	
		400	Φ56	Φ81.1	
		450	Φ52.9	Φ81.1	
		500	Φ56	Φ87.4	
		550	Φ52.9	Φ87.4	
		600	Φ56	Φ93.7	2640-SHC.AFS
		650	Φ52.9	Φ93.7	
		700	Φ56	Φ100	
		750	Φ52.9	Φ100	
		800	Φ56	Φ106.3	
		850	Φ52.9	Φ106.3	

Available options:
 • stainless tube, bearings, shaft

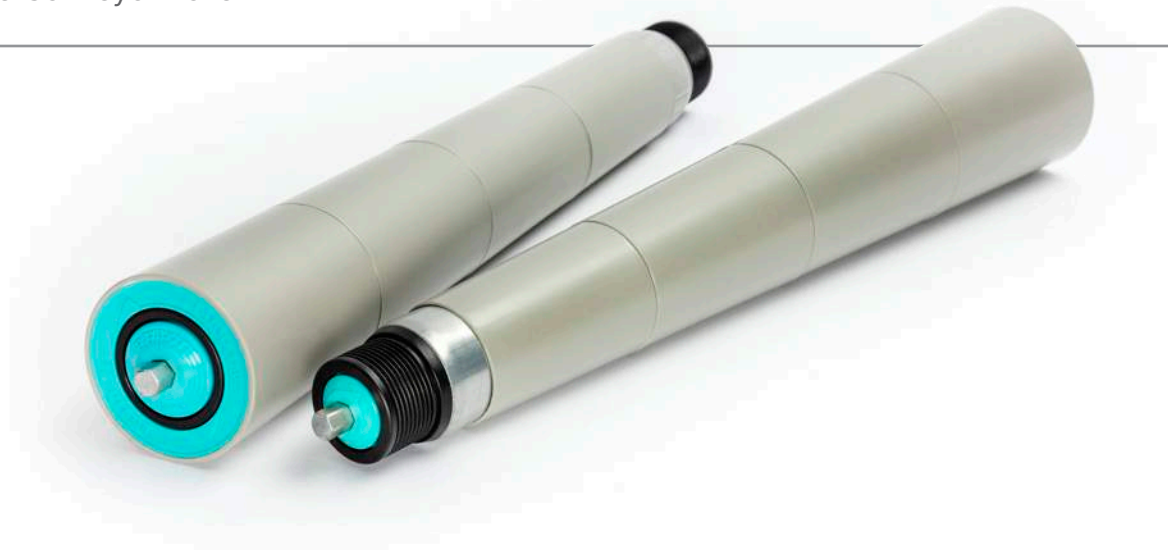

2650 Series Poly-V Tapered Sleeve Roller

Product Features:

- Based on the 2250 Series, covered with grey polypropylene taper sleeve, abrasion resistant, low noise, shockproof.
- The poly-V pulley is located on the head end of the roller which separates the drive area and the conveying area avoiding interference between the poly-V belt and the conveyed goods.
- The bearing end cap consists of a precision ball bearing, a polymer housing and end cap seal. Combined they provide a smooth and quiet running roller.
- The design of the end cap protects the bearings by providing excellent resistance to dust.
- ISO9982 PJ series poly-V. Total of 9 grooves at 2.34mm pitch.
- The duty capacity of the roller depends on the type of poly-V belt and transmission layout. The weight of single items to be conveyed should not exceed 110 lbs.
- The roller is light and easy to start-up.
- Temperature range: 40° to 104° F (-5°C – 40°C).

Specifications:

Bearing Unit	
Bearing housing	Polyamide, black
End cap	Polypropylene, daRoller green
Precision ball bearing	6002
Drive Element	
Poly-V wheel	Polyamide, black

 Optional poly-V belts are available.

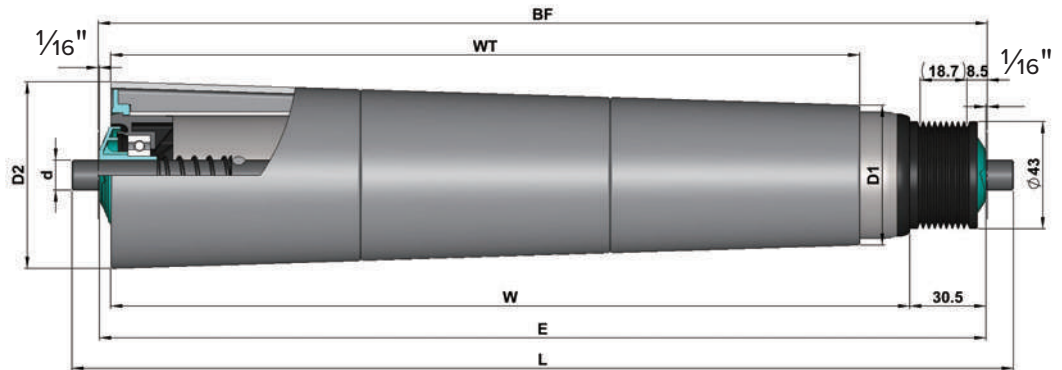

2650 Series

Tube Diameter Imperial (inches)	Tube Diameter Metric (mm)	Shaft Hex	Dimensions
Φ1.96"	Φ50	7/16"/11mm	BF = E + 1/8"

Tube	D*T	WT	D1	D2	Shaft Dia. (d)
					11hex
Steel, zinc-plated with polypropelene tapered segmented sleeves	Φ50x1.5	300	Φ56	Φ74.9	2650-SHC.AFS
		350	Φ52.9	Φ74.9	
		400	Φ56	Φ81.1	
		450	Φ52.9	Φ81.1	
		500	Φ56	Φ87.4	
		550	Φ52.9	Φ87.4	
		600	Φ56	Φ93.7	
		650	Φ52.9	Φ93.7	
		700	Φ56	Φ100	
		750	Φ52.9	Φ100	
		800	Φ56	Φ106.3	
		850	Φ52.9	Φ106.3	

Available options:
 • stainless tube, bearings, shaft



4664 Brate Drive
Suite 400
West Chester Township, OH 45011

Phone: 513.898.1850
Fax: 513.771.3244
info@daroller.com
www.daroller.com